

Flachkopf-Schmiernippel Stahl verzinkt

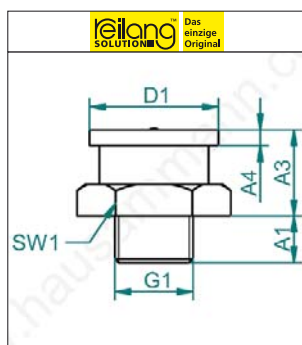

Flachkopf-Schmiernippel A2 Ø 16 mm

Stahl verzinkt, gerade nach DIN 3404 und VSM 19335/21.

Besonders geeignet, wenn die Schmierstellen mit Spezialfett geschmiert werden, keine Verwechslungsgefahr.

Artikel	G1	D1	A1	SW1	A3	A4	VP1	VE	VP2	VE	VP3
03.150	M6	16 mm	6 mm	SW17	11 mm	2 mm	1.75	100	1.08	1000	0.97
03.153	M8 x 1	16 mm	6 mm	SW17	11 mm	2 mm	1.75	100	1.08	1000	0.97
03.151	M8	16 mm	6 mm	SW17	11 mm	2 mm	1.75	100	1.08	1000	0.97
03.157	G 1/8	16 mm	6 mm	SW17	11 mm	2 mm	1.75	100	1.08	1000	0.97
03.170	1/8 NPT	16 mm	6 mm	SW17	11 mm	2 mm	1.75	100	1.08	1000	0.97
03.155	M10 x 0.75	16 mm	6 mm	SW17	11 mm	2 mm	1.75	100	1.08	1000	0.97
03.156	M10 x 1	16 mm	6 mm	SW17	11 mm	2 mm	1.75	100	1.08	1000	0.97
03.154	M10	16 mm	6 mm	SW17	11 mm	2 mm	1.75	100	1.08	1000	0.97
03.159	M12	16 mm	6 mm	SW17	11 mm	2 mm	1.75	100	1.08	1000	0.97
03.158	G 1/4	16 mm	6 mm	SW17	11 mm	2 mm	1.75	100	1.08	1000	0.97
03.171	1/4 NPT	16 mm	6 mm	SW17	11 mm	2 mm	1.75	100	1.08	1000	0.97
03.160	M16 x 1.5	16 mm	6 mm	SW17	11 mm	2 mm	1.75	100	1.08	1000	0.97
03.180	G 3/8	16 mm	6 mm	SW17	11 mm	2 mm	1.75	100	1.08	1000	0.97

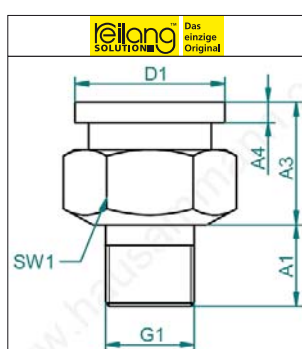

Flachkopf-Schmiernippel GIANT Ø 22 mm

Stahl verzinkt, gerade nach mit extra grossen Fettdurchlass.

Mit Platte statt Kugel für grossen Durchlass und für dicke Fette.

Kopfdurchmesser 22 mm (GIANT).

Artikel	G1	D1	A1	SW1	A3	A4	VP1	VE	VP2
03.350	1/4 NPT	22 mm	12 mm	SW22	18 mm	3 mm	8.40	100	7.20
03.500	G 1/4	22 mm	8 mm	SW22	13 mm	3 mm	3.44	100	2.43
03.450	3/8 NPT	22 mm	12 mm	SW22	35 mm	3 mm	8.40	100	7.20
03.550	G 3/8	22 mm	7 mm	SW22	13 mm	3 mm	3.44	100	2.43
03.501	M16 x 1.5	22 mm	7.5 mm	SW22	14 mm	3 mm	3.44	100	2.43